

TABLE OF CONTENTS:

System Components	1
System Level Fire Code Compliance	2
Attach Module Clips	3
Locate Array / Set-Up On Roof	3
Module to RM Bay Instructions	3
Module to RM Bay instructions - Cont.	4
Module Clip Torque Instructions	4
Ballast Block Placement Diagrams	4

PG TABLE OF CONTENTS (CONT):

Ground Lug Connection Information	5
Bonding & Grounding System Certification	6
Grounding & Bonding Procedures	7
Adding Bays - Adjustment Guide	A
Module Clip Bolt Cross Thread Information	B
Grounding Path Electrical Diagram	C

PG GENERAL NOTES:

5 Refer to construction drawings for project specific details. Construction drawings have precedence over these installation guidelines.

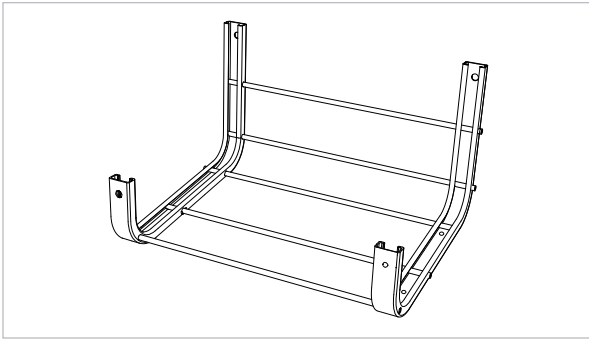

BALLAST BAY: The Ballast Bay frame is made of a mill finish Aluminum. This roof mount is a modular design that allows for easily getting around roof obstructions and accommodating roof undulations. The Ballast Bays are created such that they nest within each other to optimize shipping logistics.

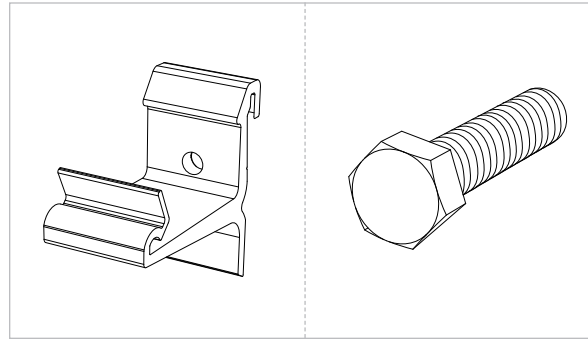

CLIP & BOLT: The Module Clip is made of a mill finish Aluminum and engages the return flange underneath the panel to secure the module. This unique design takes advantage of the design of the module frame, attaching to the return flange of the frame creating a universal connection.

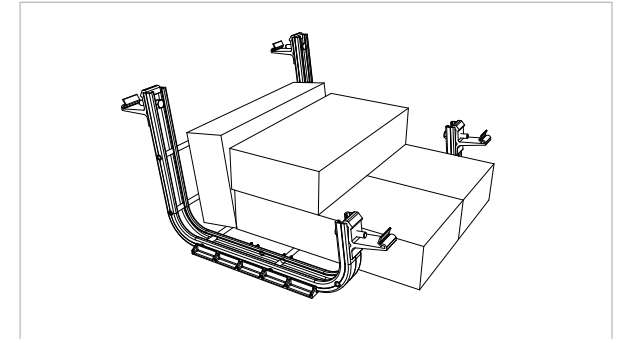

BALLAST BLOCK: The RM ballast bay can fit up to 4 standard 4"x8"x16" solid concrete cap blocks. Block weight can range from 26 – 38 lbs. The weight of the block will have a major impact on how many will be required for the project so be sure to verify your block weights before using the U-builder online tool.

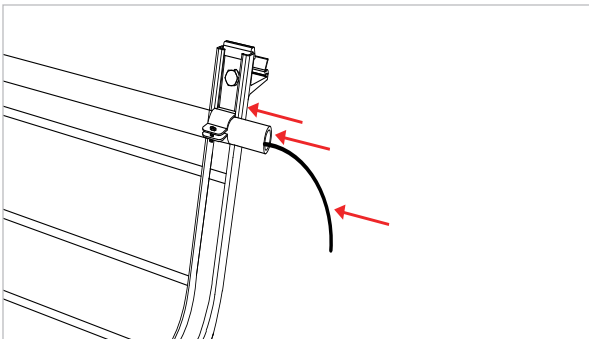

OPTIONAL WIRE MANAGEMENT: Components by others.

NOTE: All conduit and wire ways should be grounded & bonded per the (NEC) National Electric Code.

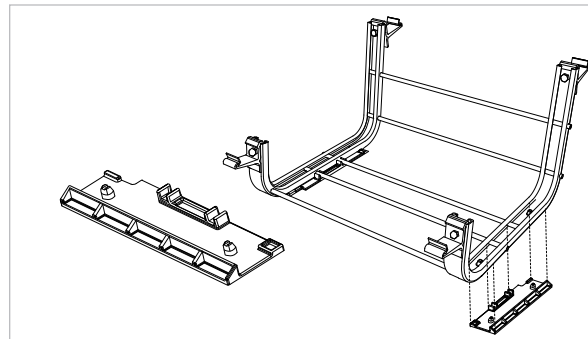

OPTIONAL ROOF PAD: The Roof Pad provide a protective interface between the Ballast Bay and roofing material to reduce any possible damage that could occur. The Roof Pad snaps into the holes on the bottom side of the Ballast Bay, two Roof Pads per bay. Please consult the roofing manufacturer to see whether it is required as well as to verify compatibility.

SYSTEM LEVEL FIRE CLASSIFICATION: The system fire class rating is only valid when the installation is conducted in accordance with the assembly instructions contained in this manual. RM Roof Mount has been classified to the system level fire portion of UL1703. It has achieved Class A performance for low sloped roofs when used in conjunction with type 1, type 2 and type 3 module constructions. System fire class rating requires a prescriptive method of mounting the module. Please see the specific conditions below for mounting details required to maintain the Class A fire rating. Minimum and maximum roof slopes are restricted through the system design and layout rules. The fire classification rating is only valid on roof pitches less than 2:12 (slopes \leq 2 inches per foot, or 9.5 degrees).

Module Type	System level Fire Rating	Mitigation
Type 1	Class A	Prescriptive. See notes & Illustration Below
Type 2	Class A	Prescriptive. See notes & Illustration Below
Type 3	Class A	None Required / No Limitations

TYPE 1 / TYPE 2 CLASS A FIRE RATING MOUNTING ORIENTATION

Unirac RM has achieved Class A system level fire performance for type 1, type 2 and type 3 module constructions. In order to maintain the fire rating for type 1 and type 2 modules, the J-Box must be oriented away from the roof edge as in the illustration below. Type 3 module constructions do not require specific mounting orientations in order to meet Class A requirements.

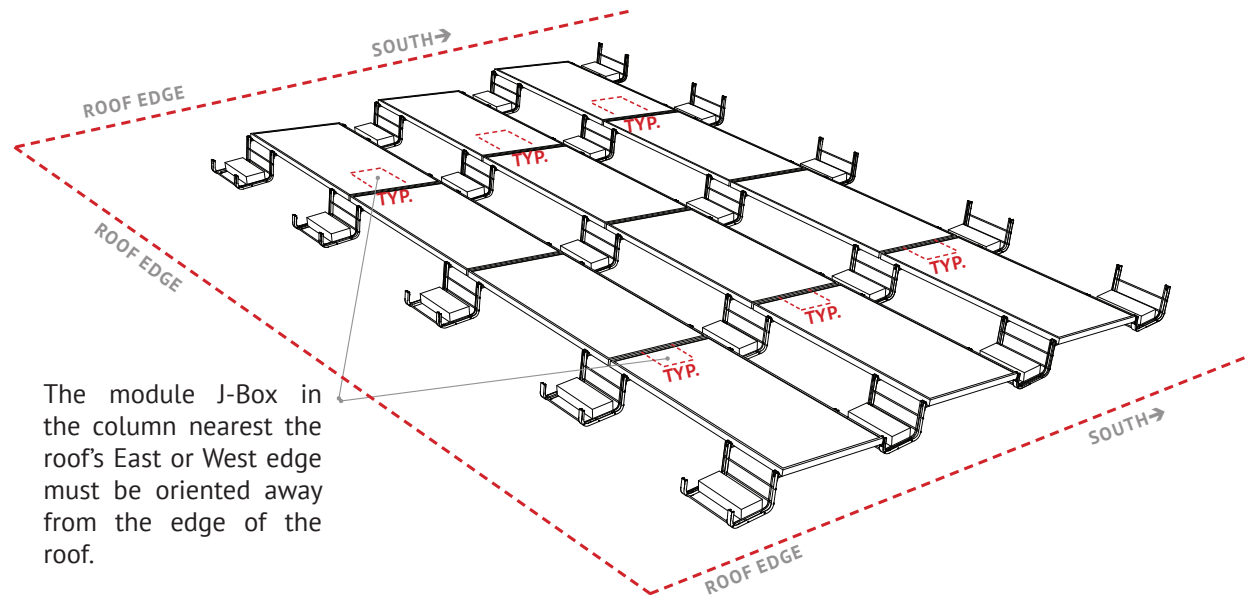

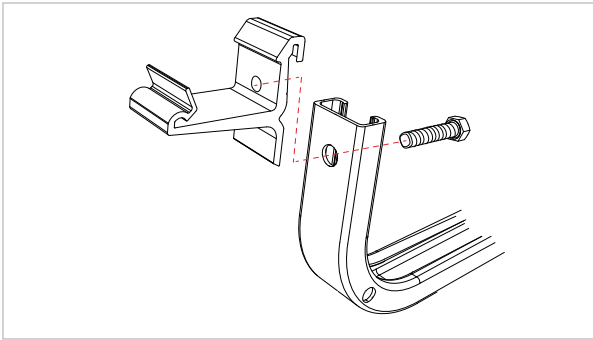

ATTACH CLIPS LOOSELY TO BAY POSTS INTENDED TO HOLD MODULES. All bolts and clips are single use only.

NOTE: BOLT - Single Use Only - Do not re-torque once fully seated.

NOTE: CLIP - Single Use Only - For complete electrical bonding path, clips must be tapped in place with hammer.

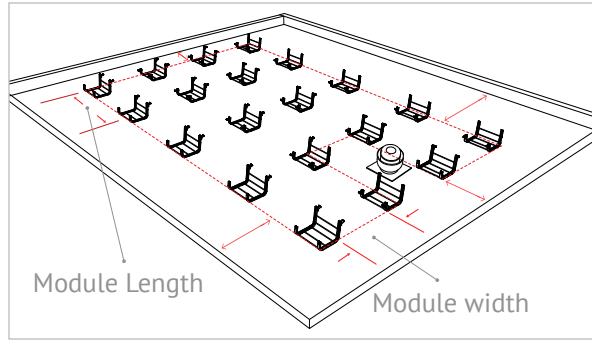

LOCATE ARRAY ON ROOF

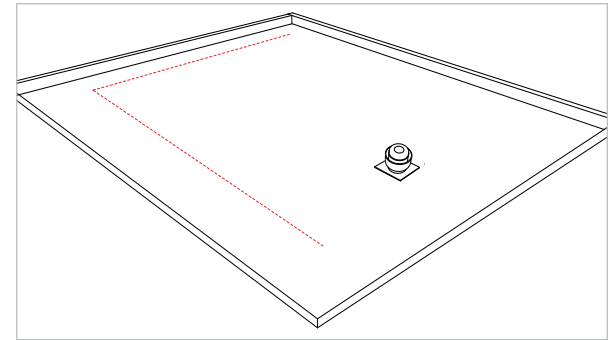

MARK ROOF WHERE ARRAY WILL START

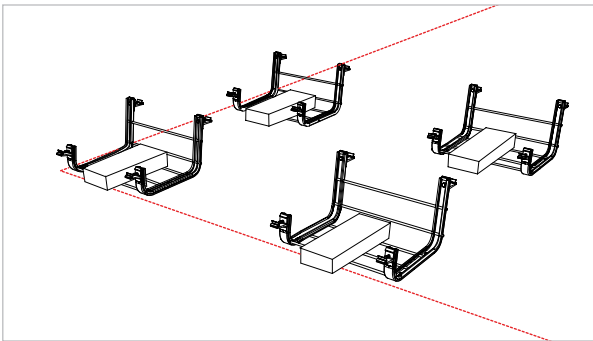

PLACE SOME BALLAST IN 1ST FOUR BAYS FOR FIRST MODULE

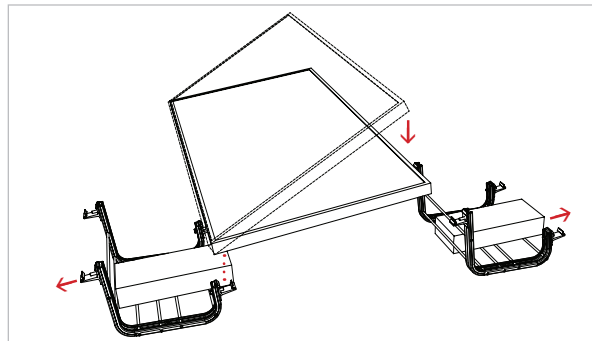

PLACE MODULE IN CLIPS

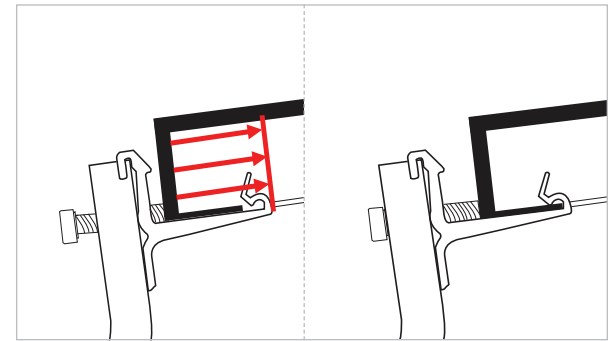

FULLY SEAT MODULE IN CLIPS AND TIGHTEN BOLTS

If module frame is not fully seated, then tightening the bolt is actually dragging ballast bays, and could result in frame damage including deformation or puncture. A gentle tug apart of the bays will seat the module into the module clip. It is NOT recommended to use the bolt to seat the module.

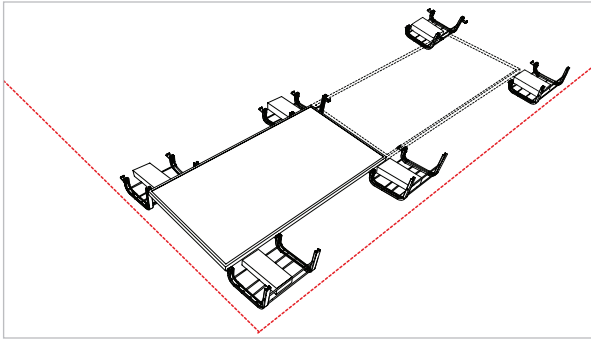

PLACE ANOTHER MODULE IN NEXT BAY CLIPS

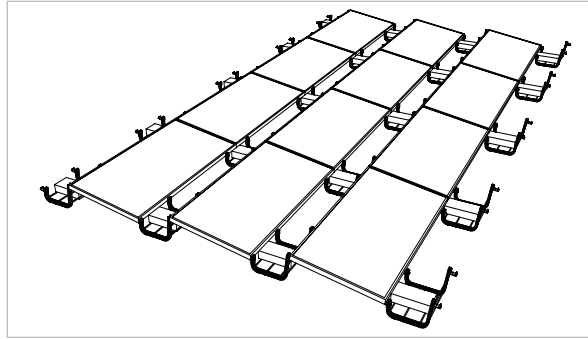

REPEAT INTERCONNECTING ADJACENTLY

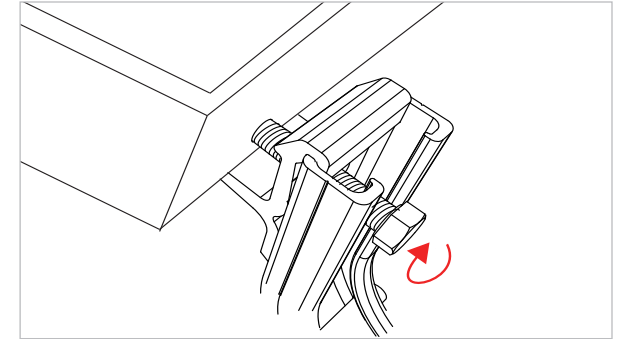

TORQUE CLIP BOLTS IN SEQUENCE

TORQUE VALUE:

7FT-LBS - Minimum - 9FT-LBS - Maximum

NOTE: BOLT - Single Use Only - Do not re-torque once fully seated.

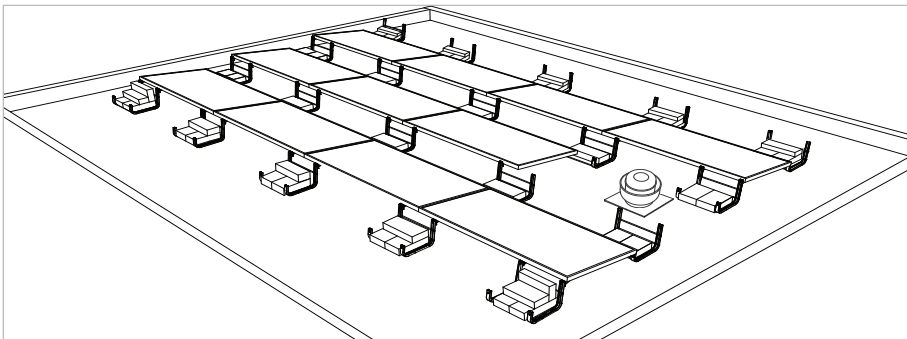

COMPLETE BALLASTED PLACEMENT: Place ballast as required. Deviations from block arrangements shown in this guide may cause shading. Site specific ballast calculations should be determined for each individual project in accordance with the U-Builder software and the Unirac Design and Engineering guide for ROOFMOUNT. This system has been rated for the mechanical load provisions of UL2703. In addition, it has been designed and tested to comply with the more rigorous requirements of SEAOC PV1, PV2 and ASCE 7.

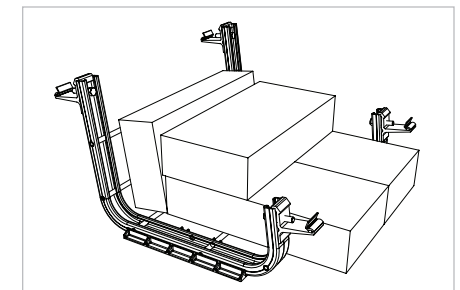
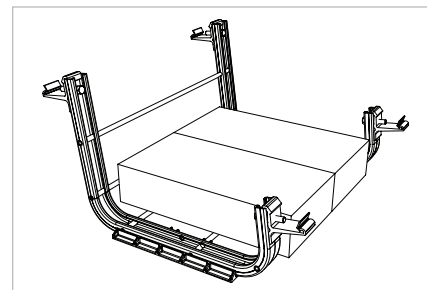
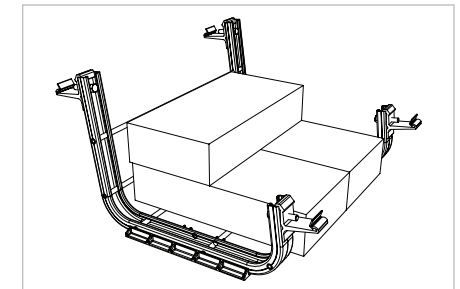
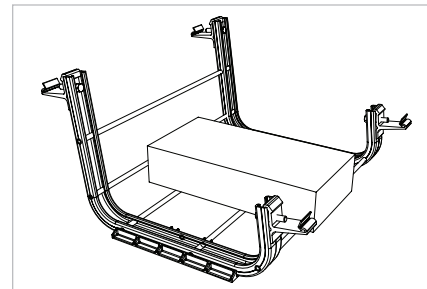

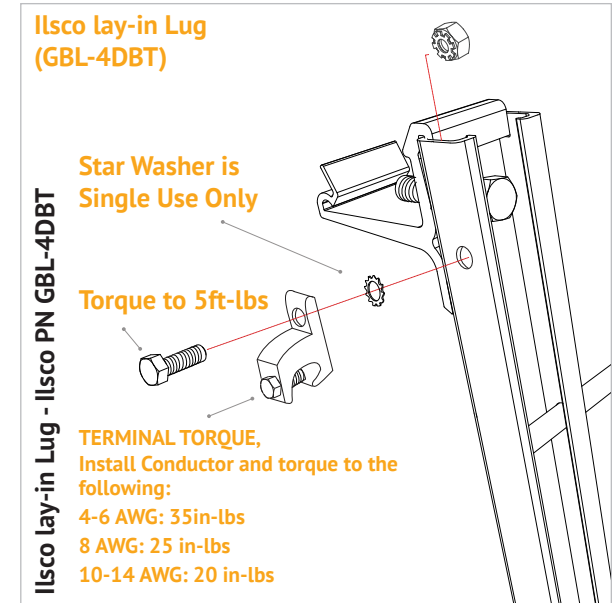
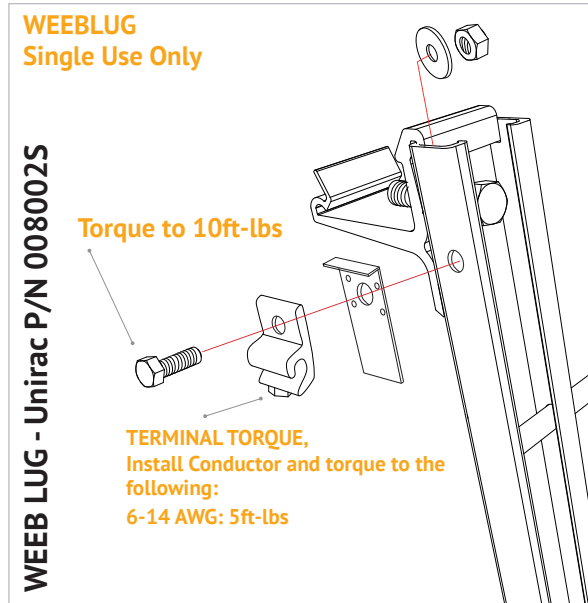
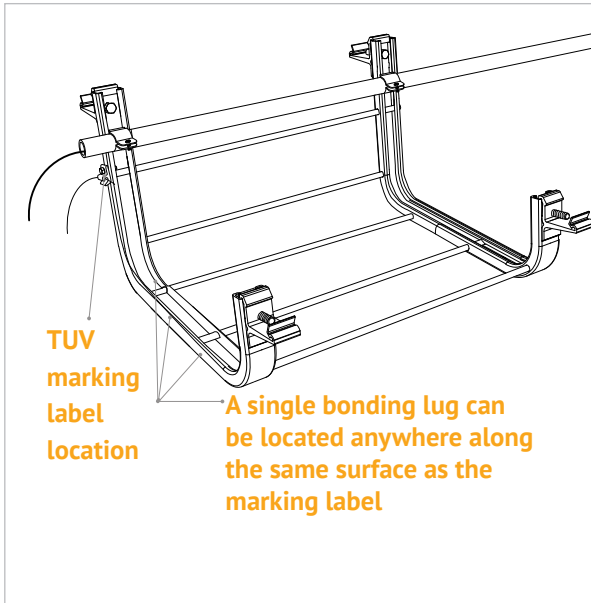

Although conformance with UL2703 was demonstrated without the use of oxide inhibitor material, it is recommended by IIsco to provide an optimized bonding solution for their lay-in lug.

GROUNDING LUG MOUNTING DETAILS AS REQUIRED BY CODE & ENGINEER OF RECORD: Details are provided for both the WEEB and IIsco products. The WEEBLug has a grounding symbol located on the lug assembly. The IIsco lug has a green colored set screw for grounding indication purposes. One lug is recommended per continuous array, not to exceed 150ft X 150ft.

Unirac Roof Mount is intended to be used with PV arrays that have a system voltage less than or equal to 1000VDC. A min. 10 AWG, 105 degrees Celsius copper grounding conductor should be used to ground a 1000 VDC system, according to the (NEC) National Electric Code and the authority having jurisdiction. It is the installers responsibility to check codes, which may vary.

NOTE: The installation must be conducted in accordance with the National Electric Code ANSI / NFPA 70.

Ground Lug	Bolt Size	Drill Size	Torque Value
WEEB Lug	1/4"-20	17/64"	10 ft-lbs
IIsco Lug	#10-32	7/32"	5 ft-lbs

ELECTRICAL BONDING & GROUNDING TEST MODULES: The modules selected for UL 2703 bonding & grounding testing were selected to represent the broadest range possible of modules on the market. The tests performed cover the following basic module parameters:

- 60, 72, and 96 cell modules
- Frame thicknesses greater than or equal to 1.0mm
- Basic single and double wall frame profile (some complex frame profiles could require further analysis to determine applicability)
- Clear and dark anodized aluminum frames
- The frame profile must not have any feature that might interfere with bonding devices that are integrated into the racking system

VERIFIED COMPATIBLE MODULES:

Module Manufacturer	Model / Series	Thickness (mm)
AU Optronics	PM Series	40
Canadian Solar	CS5A-M	40
	CS6P-M	40
	CS6P-P	40
	CS6X-P	40
Centrosolar America	C-Series	40
	E-Series	40
ET Solar	ET AC Module	40
	ET Module	40
Hanwha SolarOne	HSL 60	40
	HSL 72	40
Hyundai Heavy Industries	MI Series	35
	MG Series	35
JA Solar	JAP6 60	50
	JAP6 72	50
Jinko Solar	Standard	40
Kyocera	KD-F Series	46
LG Electronics	MONO X	35
	MONO NEON	35
Phono Solar Technology	Standard Modules	40
REC	Peak	38
	Eco	38
Renesola	All 60 cell modules	40

Module Manufacturer	Model / Series	Thickness (mm)
Sharp	ND-24CQJ	46
	ND-25CQCS	46
	ND-Q235F4	46
	ND-F4Q300	46
SolarWorld	Sunmodule Protect	31
	Sunmodule Plus	31
Suniva	Optimus Series	40
	MV Series	40
Suntech	STP "XXX"	35
Sun Edison	F-Series	50
	R-Series	50
SunPower	X-Series	46
	E-Series	46
	Sig Black	46
	AC	46
Trina	PA05	35
	PD05	35
	PD14	35
Yingli	YGE-U 72	40
	YGE-60	40
	YGE-Z 60	46
	Panda 60	40

TEMPORARY GROUNDING & BONDING PROCEDURE: Periodic inspections should be conducted on the PV array to ensure there are not loose components, loose fasteners or corrosion. If any of the above items are found, the affected components are to be immediately replaced. **If a module must be removed or replaced, a temporary bonding jumper must be used to ensure safety of the personnel and PV system.**

NOTE: Removing a PV module from a system is not considered to be routine maintenance. This type of activity should only be performed by trained and qualified installers.

NOTE: In order to prevent corrosion induced by dissimilar metals, it is important to verify that the bare copper wire does not come into contact with aluminum. These materials must be kept separate.

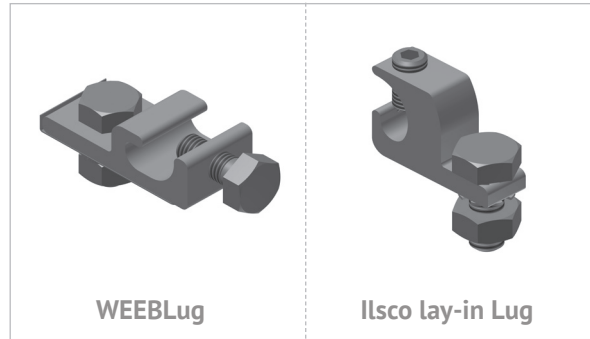

APPROVED LUGS

WEEBLug UNIRAC PN 008002S

[See product data sheet](#)

IlSCO lay-in Lug IlSCO PN GBL-4DBT

[See product data sheet](#)

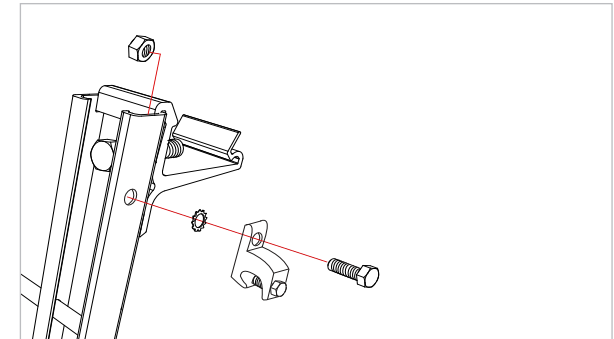

ATTACH LUGS: Use approved lug(s) to install on adjacent bays where the module is being removed.

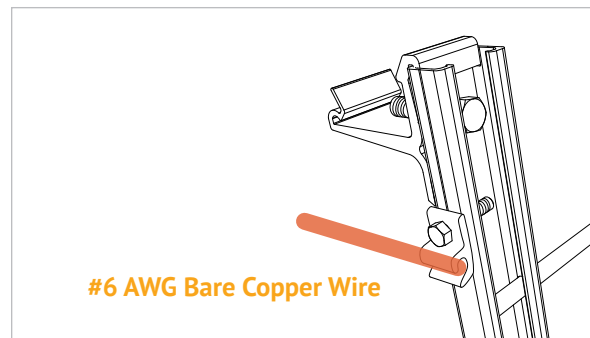

INSERT COPPER WIRE: Insert bare copper (#6 AWG) wire into each lug, providing a bonding jumper across the missing module location.

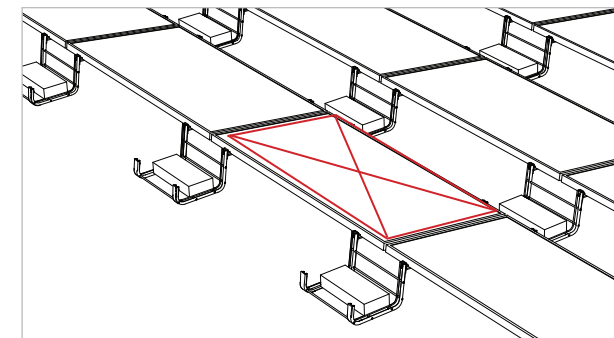

REMOVE MODULE & REVERSE THE OPERATION AFTER MAINTENANCE IS COMPLETE

NOTE: Removing a PV module from a system is not considered to be routine maintenance. This type of activity should only be performed by trained and qualified installers.

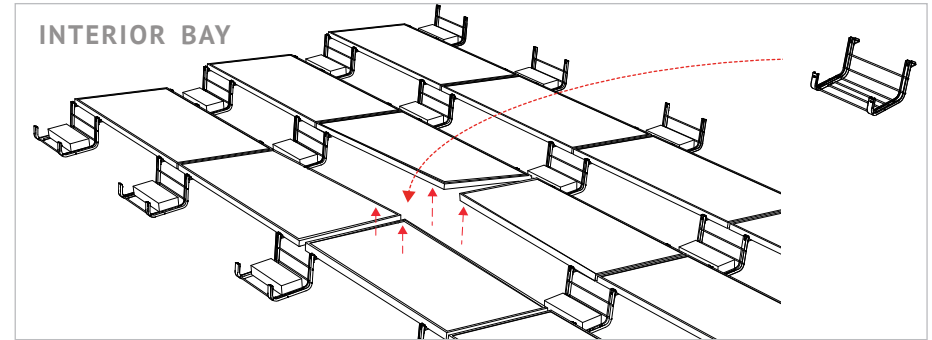
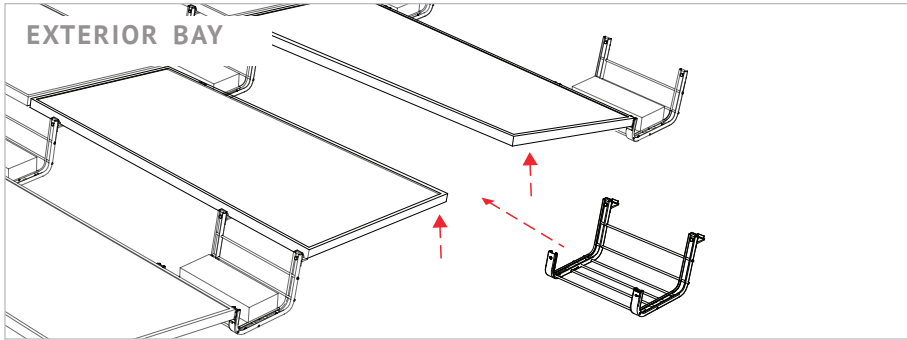

PROBLEM - ADDING BAYS AFTER INSTALLATION COMPLETED: Apply gentle, even uplift on the adjoining module frames, and maneuver bay into place

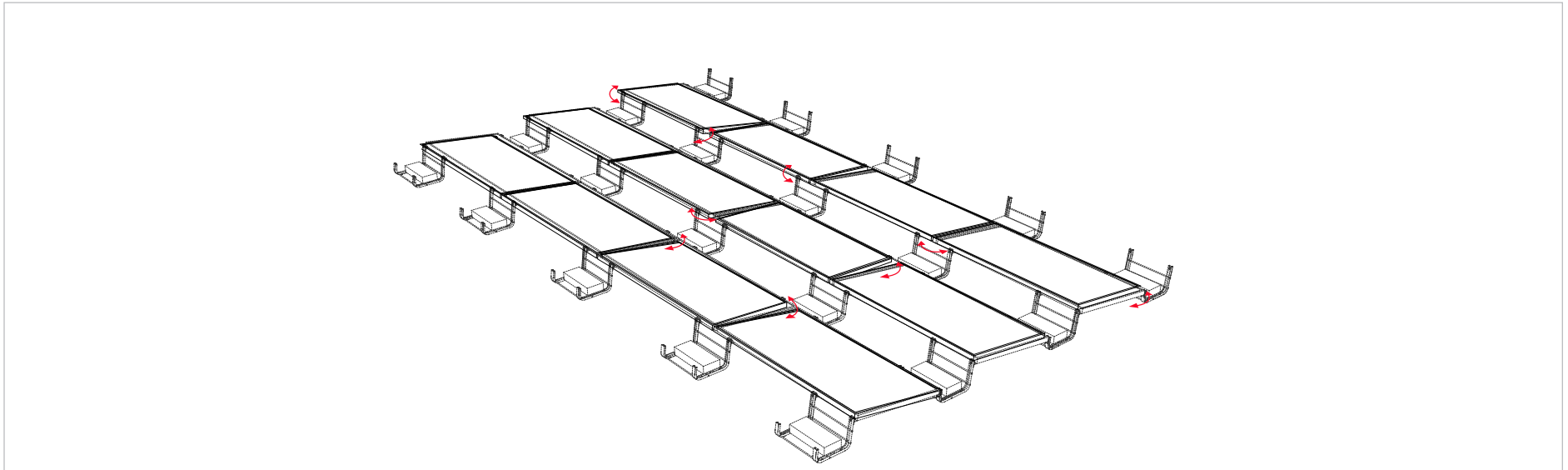

PROBLEM - ARRAY BUCKLES, OR HAS INCONSISTENT OR UN-PARALLEL GAPS BETWEEN MODULES: Loosen neighboring clips and re-adjust

- Sequentially tightening from installation outset can prevent this.

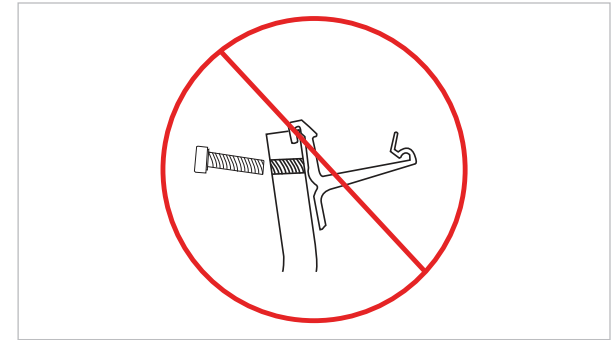
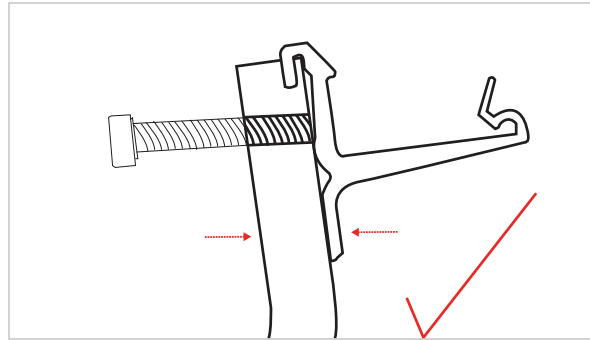
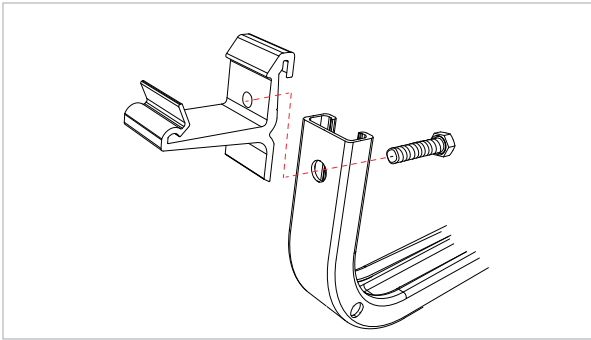

PROBLEM - CLIP BOLT CROSS-THREADS: Back bolt out and replace clip, or use thread cleaning too.

- Starting bolts with fingers instead of a power driver can minimize or eliminate cross-threading.
- When using power driver, hold it perpendicular to clip, and squeeze bottom of clip flat against bay post.

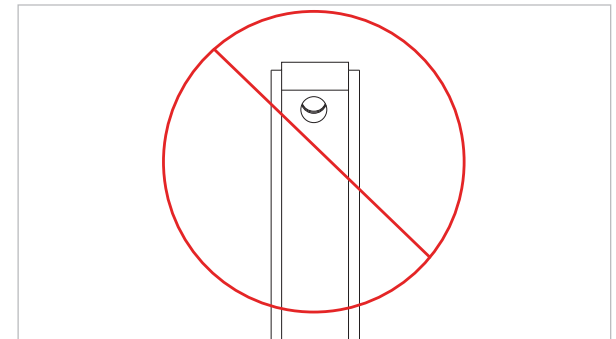
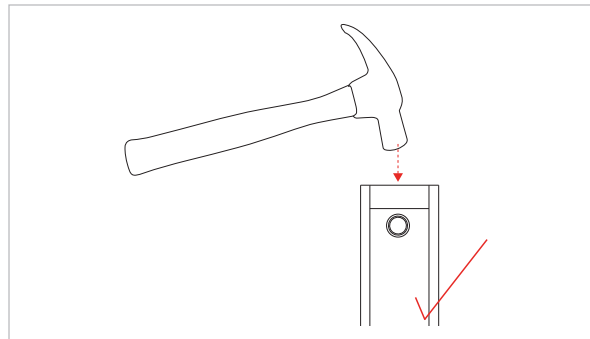
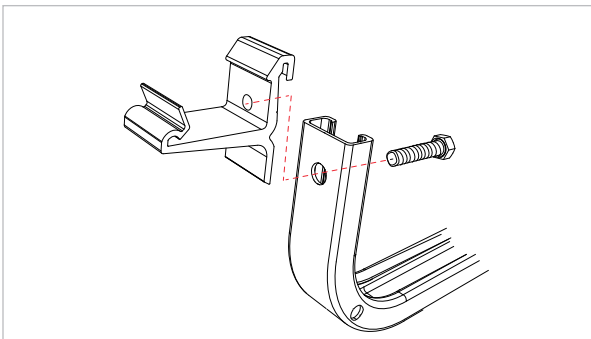

PROBLEM - MODULE CLIP THREADED HOLE AND BAY POST HOLE NOT LINED UP: Tight fit between these parts is critical for electrical bonding.

- Lining up holes may require assistance of a hammer or similar device.

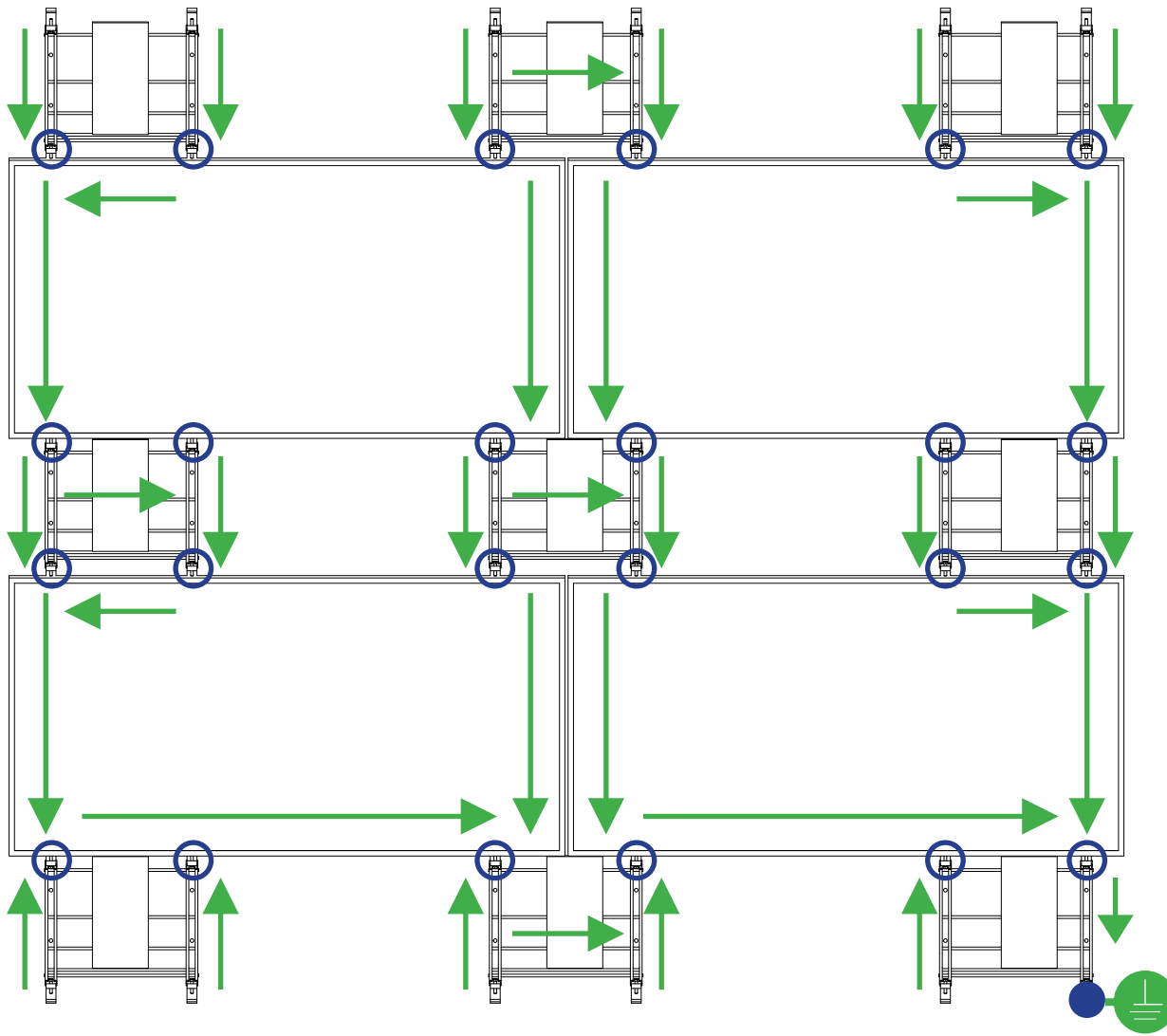

→ Fault Current Ground Path

● Ground Lug

○ Grounding Clip & Bolt

⊕ Min. 10 AWG Cooper Wire

 Module Frame

Module Bay w/
Grounding
Clips

